

TAKING

MODEL TK-300U SERIES TWO THREAD DOUBLE CHAINSTITCH HEAVY DUTY MACHINE

INSTRUCTION MANUAL & PARTS BOOK



TA KING INDUSTRIAL CO., LTD

CONTENTS

INSTALLATION	3
LUBRICATION	4
OPERAOR INFORMATION	4-7
ADJUSTMENTS.....	7-14

INDEX

INSTALLATION	3
LUBRICATION	4
ARM SHAFT	4
BED SHAFT	4
OTHER POINTS	4
SPEED	5
NEEDLES	5
SETTING	5
THREADING	6
UPPER	6
LOWER	6
PRESSER FOOT. PRESSURE	7
TENSION	7
PRESSER BAR. HEIGHT	8
STITCH LENGTH	8
FEED BAR. HEIGHT	9
FEED DOG. CENTRALIZING	9
HEIGHT	9
LENGTHWISE SETTING	9
SIDWISE SETTING	9
TIMING	10
LOOP DEFLECTOR	10
NEEDLE BAR. POSITION	10
LOOPER. POSITIONING	11
LENGTHWISE SEETING	11
SIDWISE SETTING	11
NEEDLE BAR. HEIGHT	11
TIMING	12
NEEDLE GUARD	12
SPREADER. POSITIONING.....	13
LENGTHWISE SETTING	13
SIDWISE AND HEIGHT SETTING	13
TAKE-UP. ADJUSTMENT	14
LOOPER THREAD	14
NEEDLE THREAD	14
RELEASER	14

INSTRUCTIONS FOR USING

ANTI-REVERSING MECHANISM ON MACHINES OF CLASSE 300U

Machine 300U1C, are equipped with an ANTI-REVERSING device.

To release the device, depress button located on right side of bed plate, hold down and turn machine pulley either forward or backward.

To engage the device, release button and turn machine pulley toward rear of machine until device “snaps” into place.

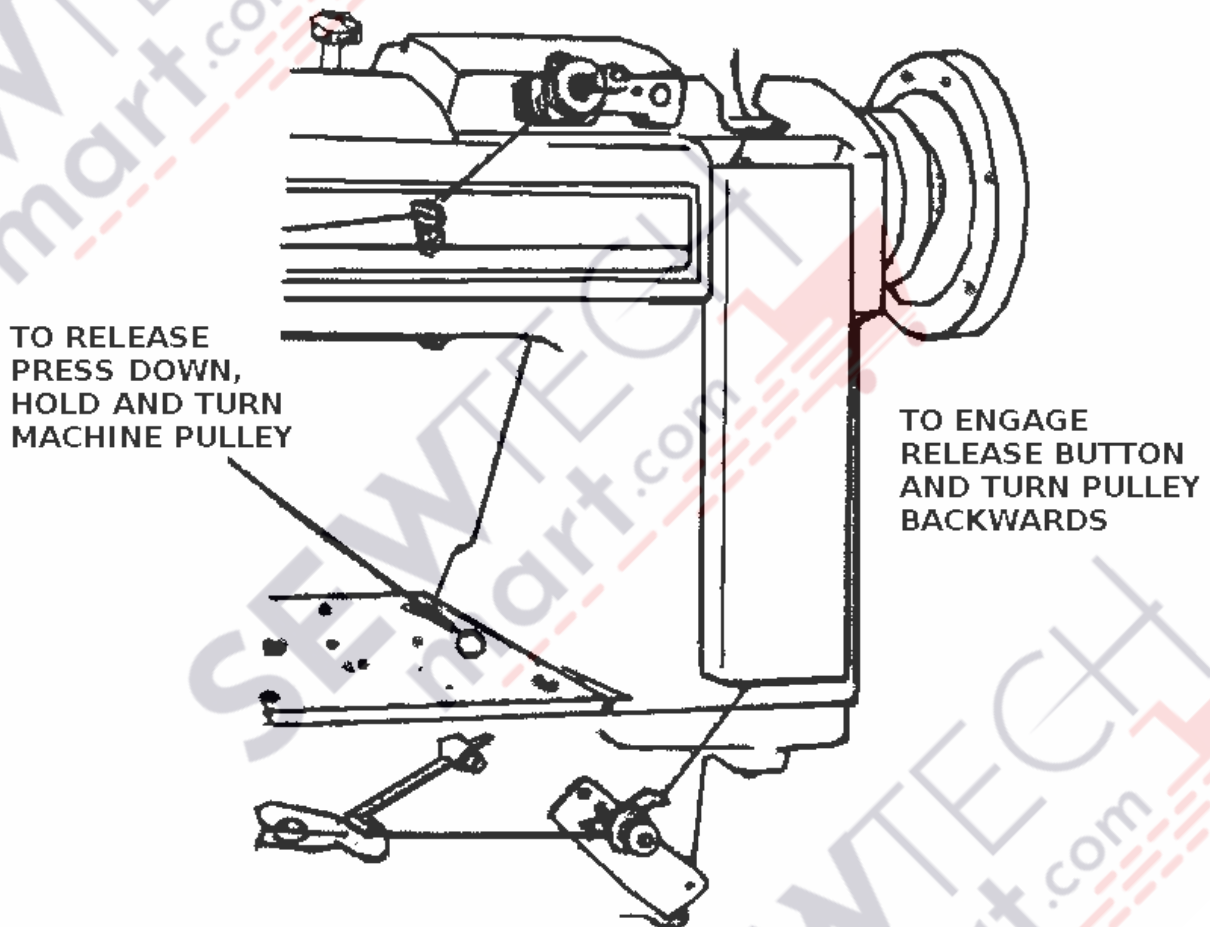

EQUALIZING THE FEEDING MOVEMENT OF THE NEEDLE FEED AND DROP FEED ON MACHINES OF CLASSE 300U

The needle feed and drop feed should not only be timed to move simultaneously, but should also move the same distance during feeding. If the drop feed moves a greater or less distance than the needle feed, depress the stitch length button and turn the machine pulley, as required, to cause the drop feed movement to equal the needle feed movement. The stitch length of both feeds can then be reset simultaneously, as described on page 8.

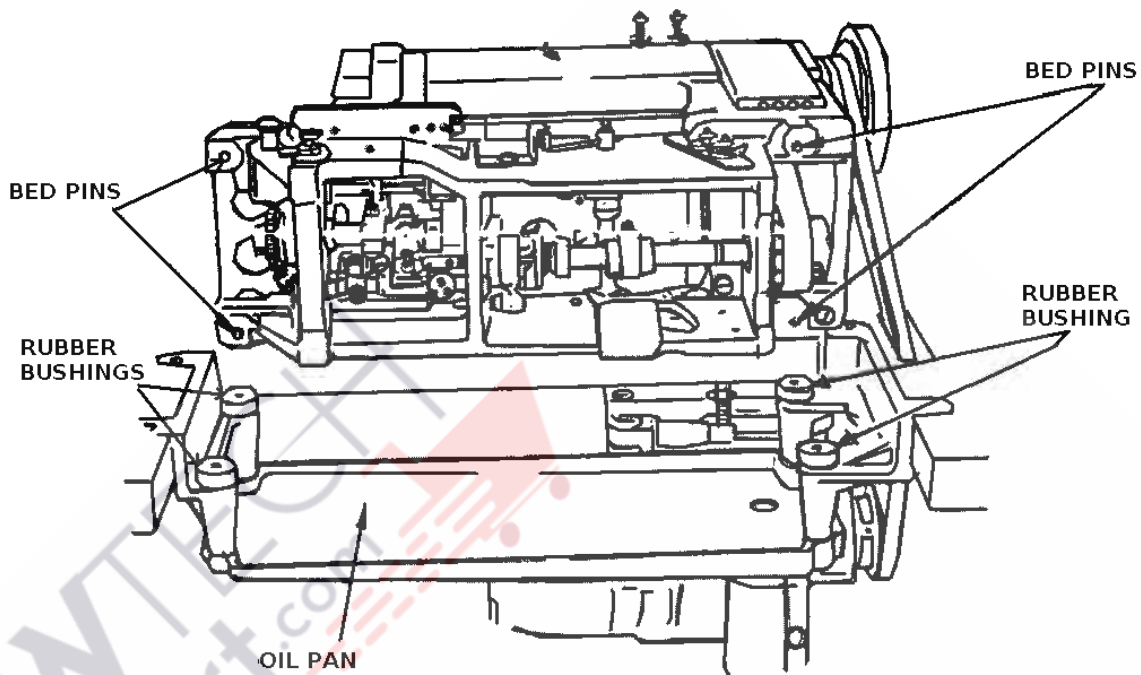

Fig. 2

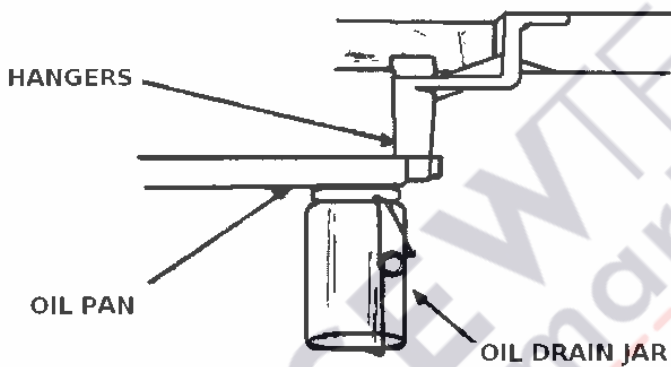

Fig. 3

INSTALLATION

Assemble oil pan to hangers. Insert assembled oil pan into machine cut-out of table placing four rubber bushings in hanger holes as shown in Fig. 2. Attach oil drain jar to oil pan as shown in Fig. 3.

Place machine on oil pa assembly with the four bed pins passing through the four rubber bushings shown in Fig. 2.

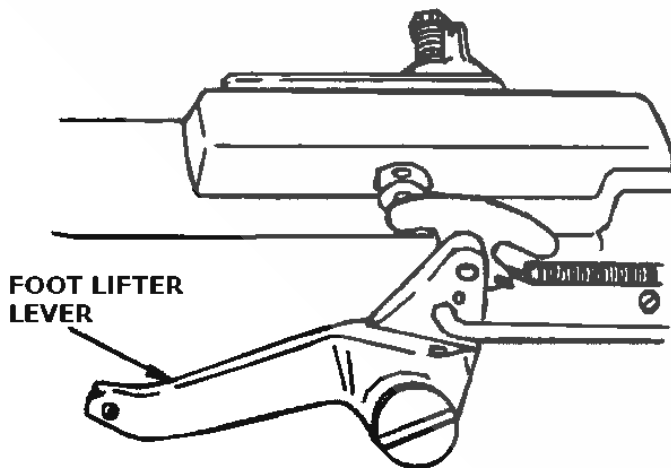

Fig. 4

Connect foot lifter treadle to foot lifter lever, Fig.4, at back of machine by chain furnished for this purpose.

LUBRICATION

Machines of class 300U have a semi-automatic lubricating system comprising a hollow arm shaft and a hollow bed shaft which act as oil reservoirs. The oil is distributed to all of the principal bearings by centrifugal force through small jets in the shafts when the machine is in operation. Provision is also made of hand lubricating other movable parts which are not lubricated from the reservoirs.

Do not use additives in sewing machine oil as they may cause a reduction in the normal flow of oil that can result in damage to the machine.

BEFORE STARTING machine, the machine must be oiled as instructed. Failure to do this will result in damage to the machine.

Pressure Oil Can, furnished with the machine, is to be used to oil all points requiring lubrication.

TO OIL ARM SHAFT

To fill arm shaft reservoir, insert spout of pressure oil can in hole, Fig.5, and inject 1 shot of oil into shaft twice daily.

TO OIL BED SHAFT

To fill bed shaft reservoir, push spring cover, Fig. 6, to the left, insert spout of pressure oil can into hole and inject 1 shoe of oil into shaft twice daily. Close oil hole spring cover.

NOTE: Bed shaft may also be oiled from right hand end of machine.

OTHER OILING POINGS

Apply oil to all work plate and arm oil holes, needle bar bearings and connections, needle bar rock frame bearings, looper rocker sleeve and presser lifting mechanism.

CAUTION: For machines in continuous use, all oiling points must be oiled daily, Occasionally oil tension release mechanism and looper pull-out rack.

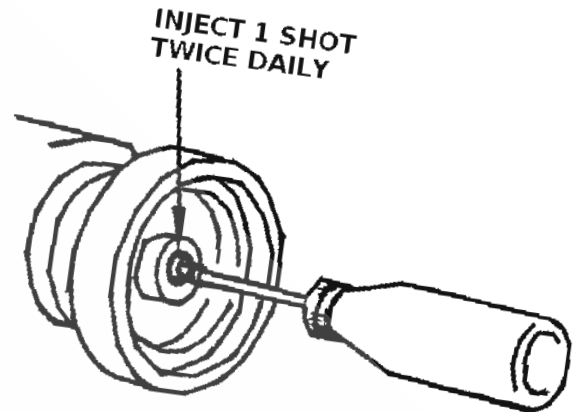

Fig. 5

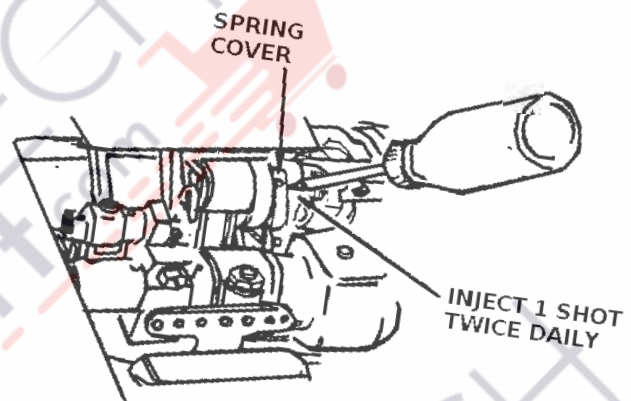

Fig. 6

For heavier weight material, needle Catalog 4112 (62x59) may also be used. In this cause, the needle bar must be adjust as instructed on page 10.

The size of the needle to be used is determined by the size of the thread which must pass freely through the eye of the needle.

Orders for needles should specify quantity required, size number and catalog number.

To Set The Needle

Turn machine pulley over toward the operator until the needle bar is at its highest point, as shown in Fig. 7.

Loosen needle set screw on single needle machines or needle clamping screws on multiple needle machines, as shown in Fig. 7.

Insert needle into needle bar or clamp as far as it will go making certain that the scarf of each needle faces toward the left, as shown in Fig. 7.

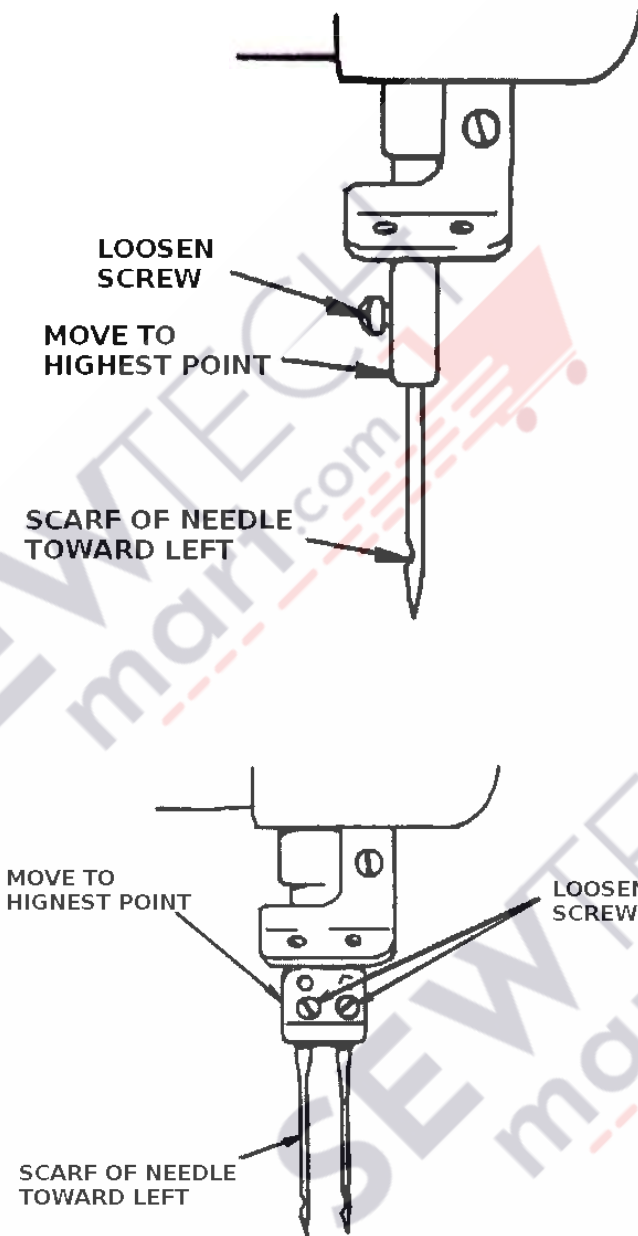

Fig. 7

THREAD

Either left twist or right twist thread may be used in the needles and loopers.

Rough or uneven thread, or thread which passes through the needle eye with difficulty will interfere with successful operation of the machine.

THREADING THE MACHINE

Upper Threading

Turn machine pulley over toward operator until needle bar is at its highest point. Pass thread from unwinder through threading points indicated in Fig. 8. See insert, Fig.8 for correct threading of needle.

Draw approximately two inches of thread through needle eye with which to start sewing.

Single and multiple needle machines are all threaded as shown in Fig. 8. Make certain that each thread passes through thread tension device.

Machines of Class 300U having Alternating Pressers are equipped with a thread lubricator on front of the arm. The needle thread must pass through the lubricator.

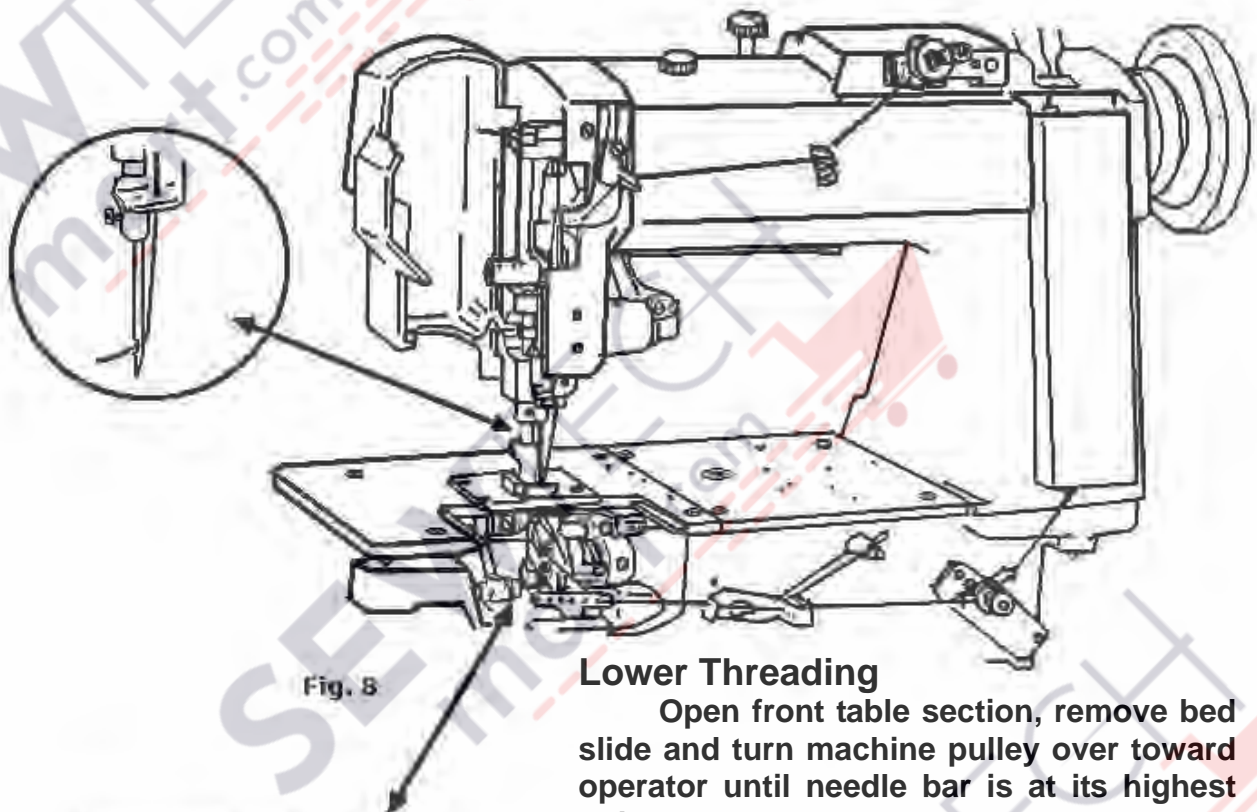

LOOPER THROW-OUT
RACK ROD

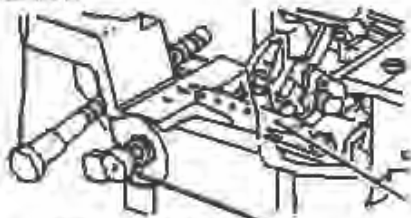

LOOPER THROW-OUT
GEAR LOCKING PLUNGER ROD

Lower Threading

Open front table section, remove bed slide and turn machine pulley over toward operator until needle bar is at its highest point.

Move loopers out of sewing position by pulling looper throw-out gear locking plunger rod and looper throw-out rack rod, Fig. 8, out as far as possible. This will place loopers in position for easier threading and prevent accidental operation of machine until loopers are returned to sewing position.

Threading The Loopers

Pass thread from unwinder through threading points as indicated. Draw approximately two inches of thread through looper eye with which to start sewing.

NEEDLE THREADS

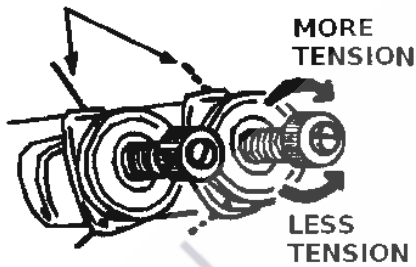

Fig. 9

TENSION

Tension on thread should be light as possible while still sufficient to set the stitch correctly in material.

Needle Thread Tension

To regulate needle thread tension, turn thumb screw, indicated in Fig. 9, as may be required.

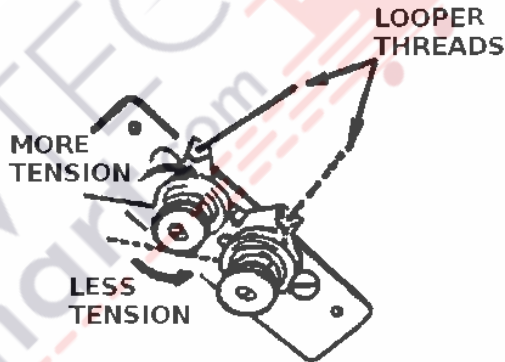

Fig. 10

IMPORTANT: Regulate needle thread tension only when presser foot is down.

Looper Thread Tension

To regulate looper thread tension, turn thumb screws, as indicated in Fig. 10, as may be required.

Alternating Presser with Penumatic Pressure Control:

Adjust height of Pressure Cylinder with presser feet resting on throat plate. There should be a clearance of 6.4mm between the Presser Bar Spring Fork and the bottom of the cylinder. To raise cylinder, loosen lower lock nut and tighten upper lock nut, see Fig. 11. To lower cylinder, loosen upper lock nut and tighten lower lock nut. When correct adjustment is attained, tighten both lock nuts.

Resulate air pressure. The correct air pressure is set for average feeding when the Presser bar spring For rises to approximately 1.9mm from the bottom of the cylinder.

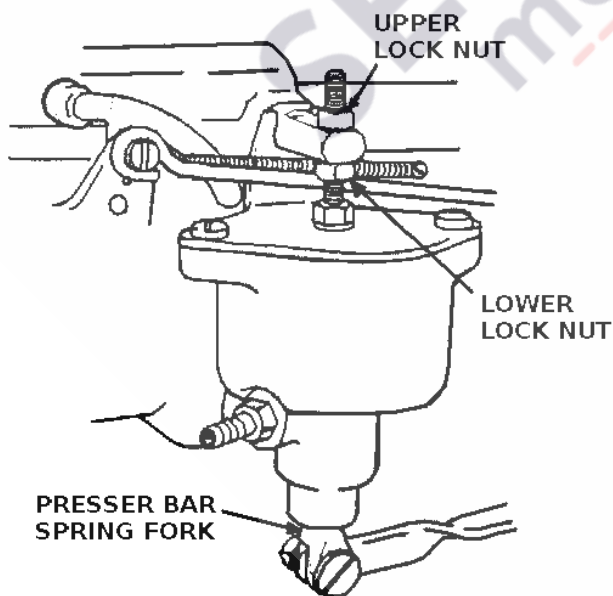

Fig. 11

STITCH LENGTH

To adjust the stitch length, depress plunger, Fig. 12, located on top of arm. Continue to hold plunger down and turn machine pulley toward operator until plunger enters notch in arm shaft eccentric. Then turn plunger to lock in position. Depress button, Fig 12, located on machine bed. Hold down, and turn machine pulley toward operator to increase length of stitch, or away from operator to decrease length of stitch, letter "A" on machine pulley indicates the longest stitch. When desired length, indicated by letter, is opposite arrow on front of machine, release button and turn plunger to right or left until it springs outward.

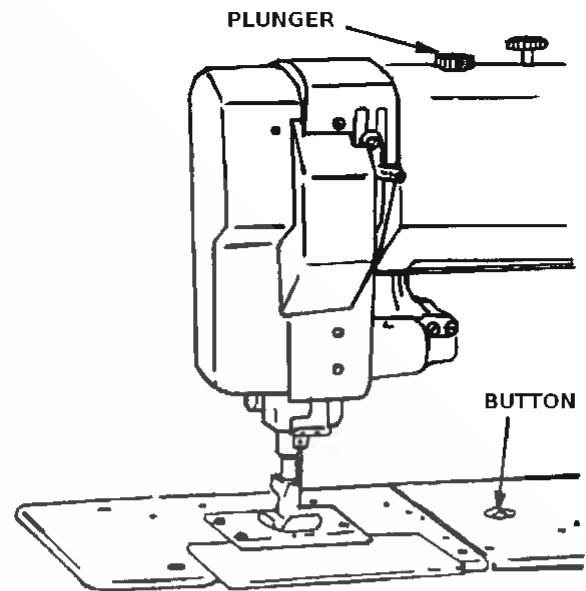

Fig. 12

CAUTION: Limit lift of pressers to minimum required for the work, as this permits higher speeds.

Machines with Alternating Pressers

The lift of the vibrating and lifting pressers is controlled by an adjustable eccentric. To adjust, remove arm cover at rear of machine. Turn machine pulley over toward operator until feeding presser is down. Loosen the two lock screws, Fig. 13, and the two clamp screws. Insert screw driver into notch of adjusting disc, and turn machine pulley as indicated in Fig. 13. Then tighten the two clamp screws and the two lock screws.

The vibrating presser should be timed so that under normal sewing conditions, the presser foot will seat on the material at approximately the same time the needle enters material. This timing can be advanced or retarded slightly depending on the type of operation being performed, such as sewing over seams. To adjust, loosen two holding screws, Fig. 14, not more than one half turn. Then turn the adjustable eccentric, Fig. 13, until the vibrating presser seats at the correct time. Securely tighten the two holding screws after adjustment is made.

When it is desirable to have either one of the pressers lift higher than the other, turn machine pulley over toward operator until the lifting presser is at its highest position. Loosen the two clamp screws, Fig. 14, and turn lifting rock shaft crank up or down until desired lift of each presser is attained. Then tighten the two clamp screws

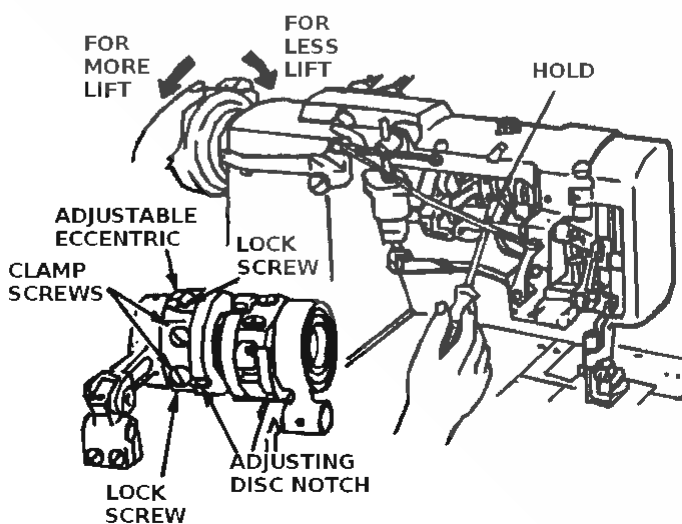

Fig. 13

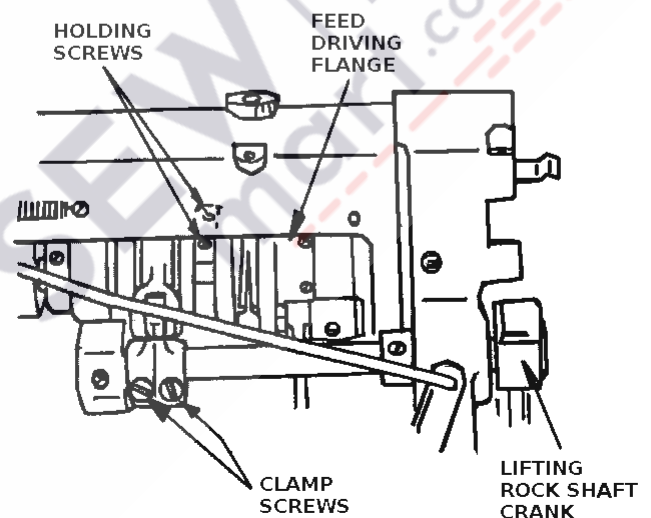

Fig. 14

TO SET FEED BAR AT CORRECT HEIGHT

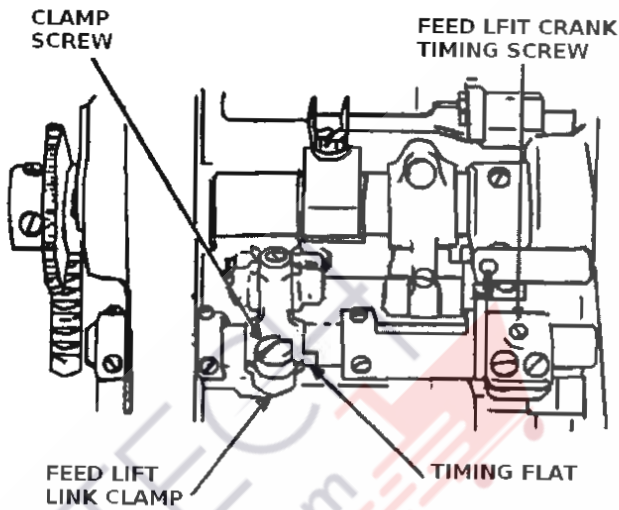

Fig. 15

When the feed bar is set at the correct height, the feed lift link clamp will be aligned with the rock shaft timing flat. To adjust, make certain that the feed lifting crank timing screw, Fig.15, engages shaft spot correctly. Loosen clamp screw and move the feed lift clamp link to correct position. The tighten clamp screw.

CENTRALIZING FEED DOG

Sidewise Setting

Needle should enter needle hole of feed dog with the same clearance between the needle and left or right side of hole. To adjust, loosen feed dog screws, Fig. 16. Move feed dog until correct clearance is attained. Hold in position, and tighten feed dog screws.

Additional adjustment, if necessary, may be attained by loosening the four rock shaft collar set screws, the two rock shaft crank clamp screws. Fig. 16, and feed lifting clamp screw, Fig. 15. Move complete assembly to required position and tighten screws.

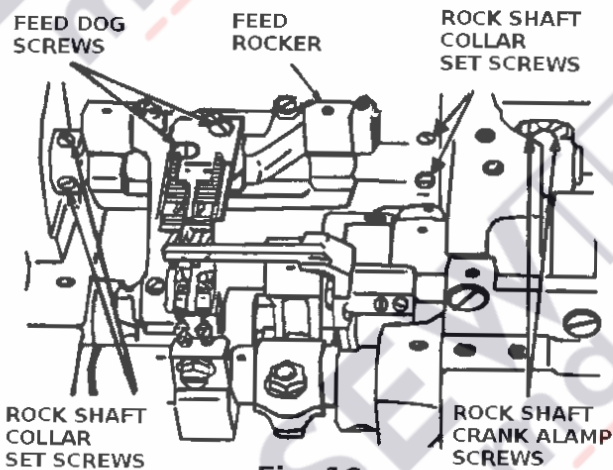

Fig. 16

Lengthwise Setting

The feed dog should clear the ends of the feed slots in the throat plate equally at both ends of feed travel. To adjust, set feed for desired stitch length. Loosen the two rock shaft crank clamp screws, Fig. 16. Move feed rocker forward or backward until correct positioning is attained. Then tighten the two clamp screws.

SETTING FEED DOG AT CORRECT HEIGHT

When the feed dog height is set correctly, approximately the full depth of the teeth will show above the throat plate. To adjust, loosen lock nuts, Fig.17, and slightly loosen feed dog clamping screw. To raise feed dog turn jack screw clockwise; to lower turn jack screw counter-clockwise and tap feed dog down. When correct setting is attained, tighten the clamping screws and lock nuts.

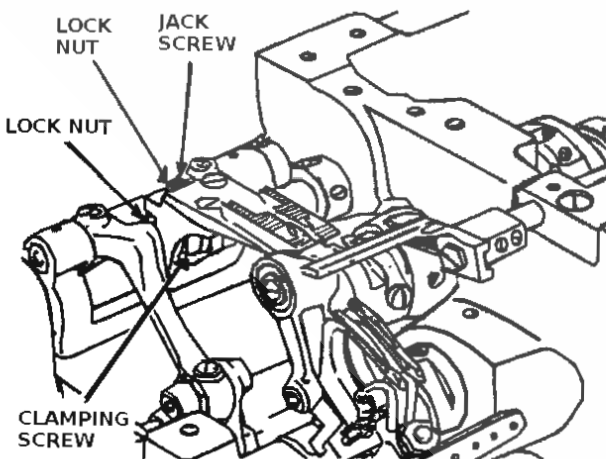

Fig. 17

TIMING FEED LIFT ECCENTRIC

When the feed dog is at its highest position, the top of the teeth should be parallel with, and project full depth of teeth above upper surface of throat plate. To adjust, insert screwdriver in hole in feed strap and loosen the two set screws, Fig.18. Move feed lift eccentric forward for earlier rise of feed dog, or backwards for later rise. Then tighten the two set screws.

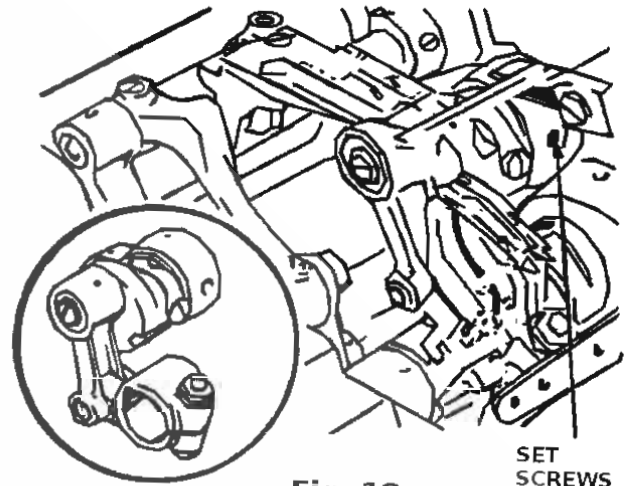

Fig. 18

SET
SCREWS

NEEDLE BAR POSITIONING

Needles should enter needle holes of feed dog toward the front with approximately the same clearance between the front of the needle and the needle holes as at the side. To adjust, press needle bar rock frame, Fig.19, against drive arm, and at the same time loosen the two driving arm clamp screws. Continue holding the rock frame against the drive arm, move needle bar to correct position and tighten the two clamp screws.

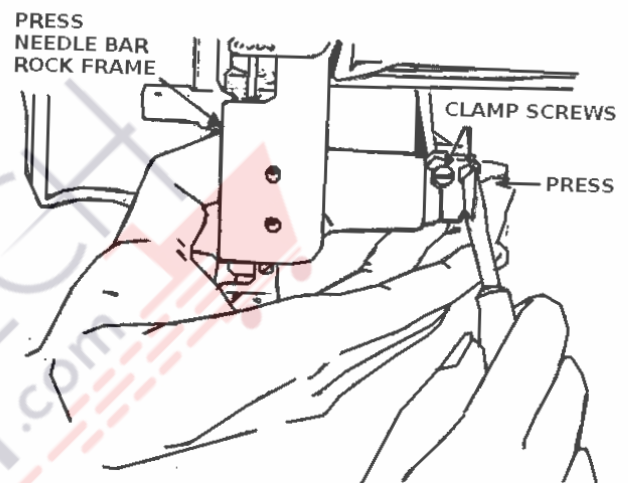

Fig. 19

POSITIONING LOOP DEFLECTORS

When loop deflector, located on underside of feed dog, is positioned correctly, there should be a clearance of

approximately 0.8 mm between the right side of the needle and the loop deflector. To adjust, move looper out of sewing position and tilt machine back on its hinges. Loosen loop deflector screws, Fig.20. Move deflectors toward rear of feed dog as far as the screw slots allow. Tighten slightly to allow for further adjustment. Return looper to sewing position and turn machine pulley until needle bar has descended to bottom of the needle bar stroke. Tap deflector to left or right until correct clearance is attained. Move looper out of sewing position and tighten loop deflector screws.

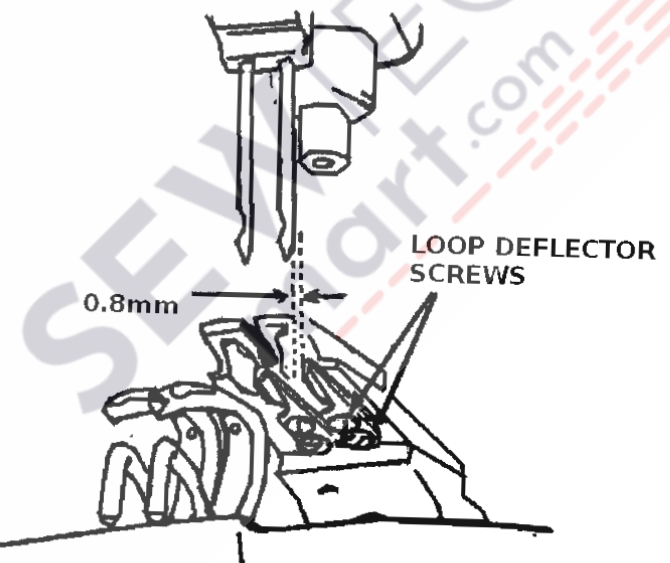

Fig. 20

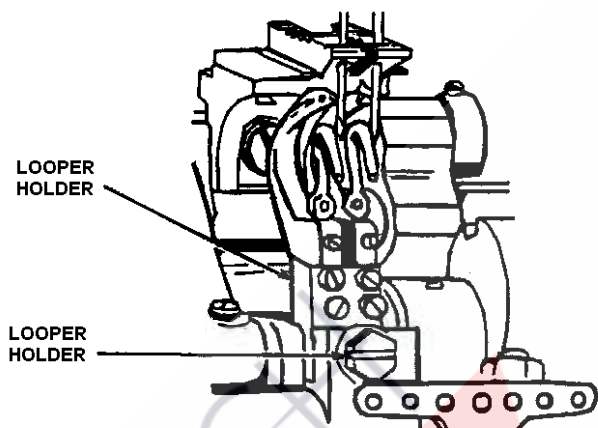

Fig. 21

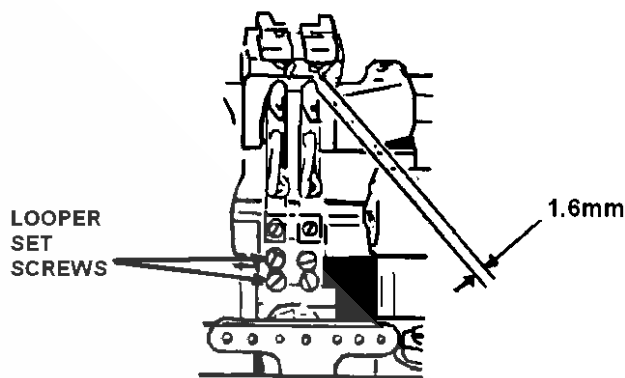

Fig. 22

SETTING THE LOOPER AT CORRECT DISTANCE FROM NEEDLE

Sidewise Setting

When the looper is correctly positioned, the point of the looper just clears the scarf of the needle on the forward stroke of the looper. To adjust, turn machine pulley until the looper point is directly apposite the center of the needle. Loosen looper holder screw, Fig. 21, and tap holder to left or right until correct clearance is attained. Then securely tighten the looper holder screw.

Move looper to extreme forward position. Check clearance between heel of looper and loop deflector, Fig. 22, which should be approximately 1.6 mm. To adjust, loosen the two looper set screws. Turn looper to left or right until correct clearance is attained. Hold in position and securely tighten the two set screws.

CAUTION: On single and multiple needle machines, make certain that the point of each looper just clears the scarf of its respective needle. To adjust, with looper point directly opposite center of needle, loosen the two set screws, Fig. 22, and turn looper slightly to left or right. Then tighten the set screws.

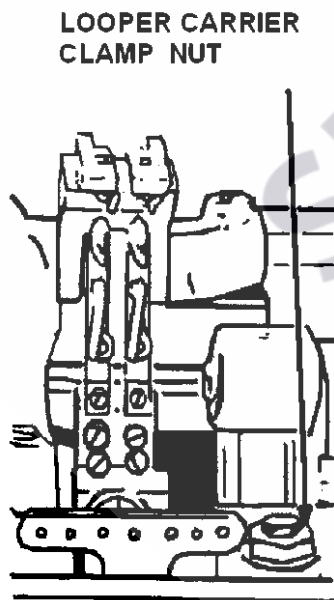

Fig. 23

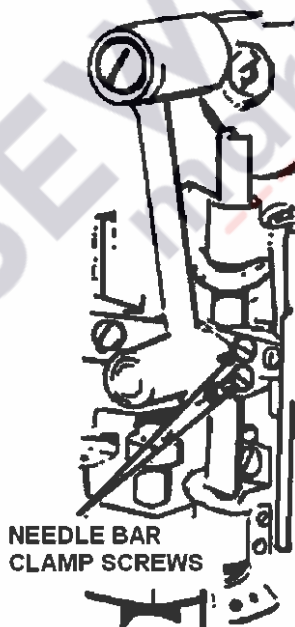

Fig. 24

Lengthwise Setting and Setting Height of Needle Bar

When correctly set, the point of the looper should be directly opposite the center of the needle, and at the center of the clearance above the eye of the needle when the looper timing mark LT on machine pulley is opposite the timing arrow on the arm.

To adjust the looper, loosen looper carrier clamping nut, Fig. 23. Move carrier forward or backward until looper point is directly opposite center of needle. Then tighten clamping nut.

To adjust needle bar, first make certain that needle is inserted up into the needle bar or clamp as far as possible. Loosen the two needle bar clamping screws, Fig. 24, and raise or lower needle bar to correct position. Then securely tighten the two clamping screws.

TIMING LOOPER DRIVING CRANK

When the looper driving crank is properly timed, the point of the looper will pass above the eye of the needle at the same distance on both the forward and backward strokes of the looper.

To adjust when point of looper passes higher on forward stroke, loosen looper driving crank set screw, Fig. 25. Loosen looper crank timing screw (left) approximately 1/8 turn, and tighten looper crank timing screw (right). Continue to adjust until correct adjustment is made. Then securely tighten set screw.

When point of looper passes higher on backward stroke, reverse the adjustment by loosening timing screw (right) and tightening timing screw (left).

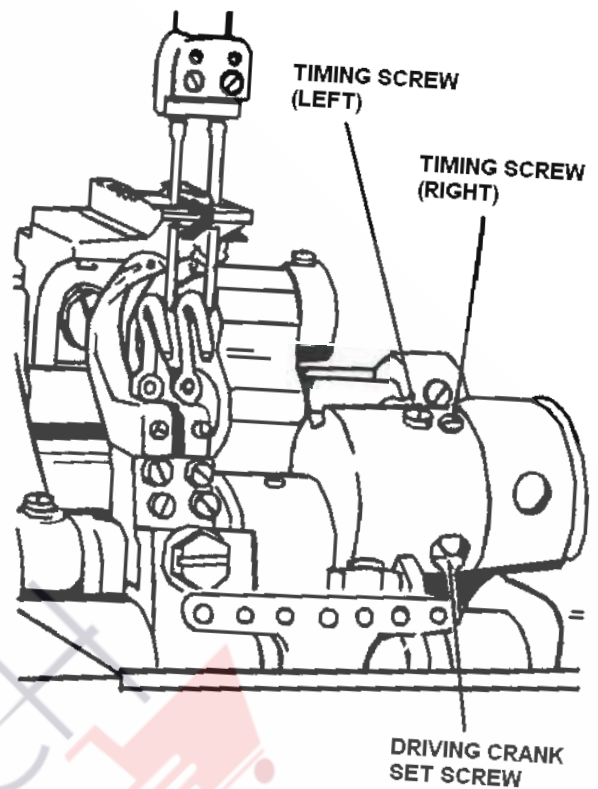

SETTING THE NEEDLE GUARDS

When needle guards are properly set, they should pass as close as possible to the needles without touching. To adjust, turn machine pulley over toward operator until the points of the loopers are about to pass the needle on their forward strokes. At this point, the looper timing mark LT on the machine pulley should be approximately 3.2 mm above the arrow on machine arm. Loosen needle guard set screws, Fig. 26. Turn needle guards as close to the needles as possible without touching. Tighten set screws. Check by springing the needle to the left and turning the machine pulley to make certain that the looper points do not stroke the needle.

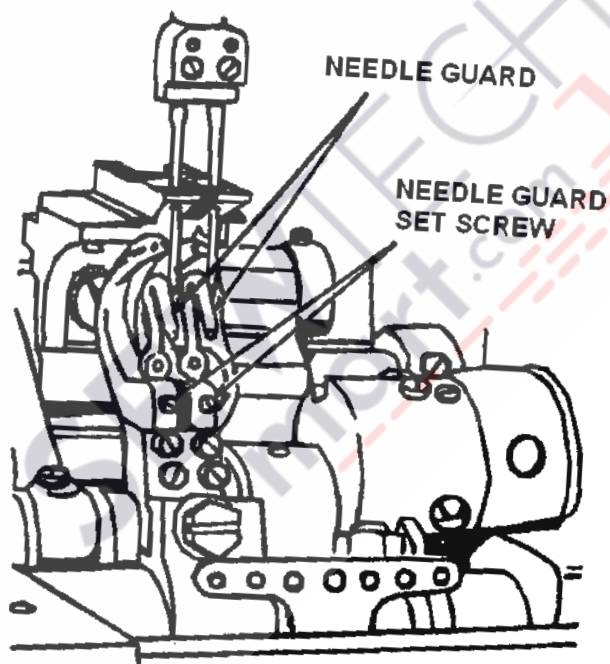

Fig. 26

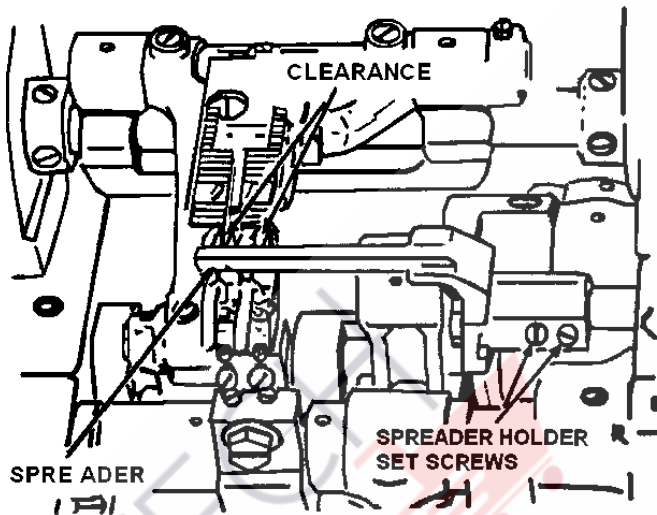

Fig.27

POSITIONING SPREADER

Sidewise and Height Setting

When looper on its forward stroke is passing spreader.....

The point of the spreader should be exactly opposite top of thread groove at left side of looper.

The clearance between spreader point and looper should be approximately the double thickness of ordinary paper.

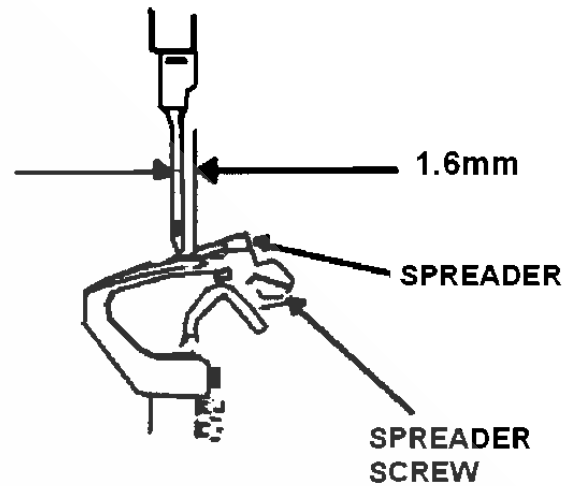

Fig. 28

To adjust, loosen the two spreader holder set screws. Fig. 27. Move spreader and holder to correct position. Hold in position and tighten the set screws.

Lengthwise Setting

When the point of the needle on its downward stroke is even with the point of the spreader, the clearance between the two points should be approximately 1.6 mm. To adjust, loosen spreader screw. Fig. 28, and move spreader forward or backward to correct position. Then tighten spreader screw.

CHANGING MOVEMENT OF SPREADER

The sidewise movement of the spreader may be adjusted for sewing under abnormal conditions. Under normal conditions, maximum spreader movement is generally used. To adjust, tilt machine back on its hinges, loosen the two spreader driving eccentric screws, Fig. 29, and the two spreader driving eccentric flange screws. Move eccentric to left to increase movement, or to right to decrease movement. When correctly positioned, tighten the two spreader driving eccentric screws first, hold flange against strap and tighten flange screws. Then refer to preceding information regarding positioning of spreader.

CAUTION: When increasing sidewise movement, allow sufficient clearance between spreader driving rock shaft, Fig. 29, and left side of eccentric ball strap. They should not touch when eccentric ball stud is in its highest position.

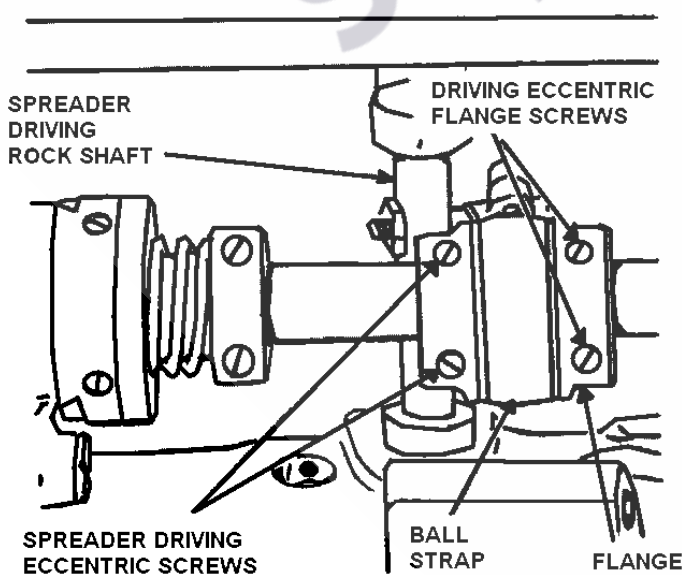

Fig. 29

ADJUSTING NEEDLE THREAD TAKE-UP

The needle thread take-up and thread guide may be adjusted to increase or decrease the amount of thread draw at the top of the needle bar stroke. To increase the amount, loosen thread take-up set screw, Fig. 30, and raise take-up or loosen guide screw and lower the guide. To decrease the amount, reverse the adjustment by lowering the take-up or raising the guide.

For average sewing conditions the guide should be set with upper end 16 mm above the guide screw. The thread take-up should be set with the lower end 35 mm below the bottom of its holder.

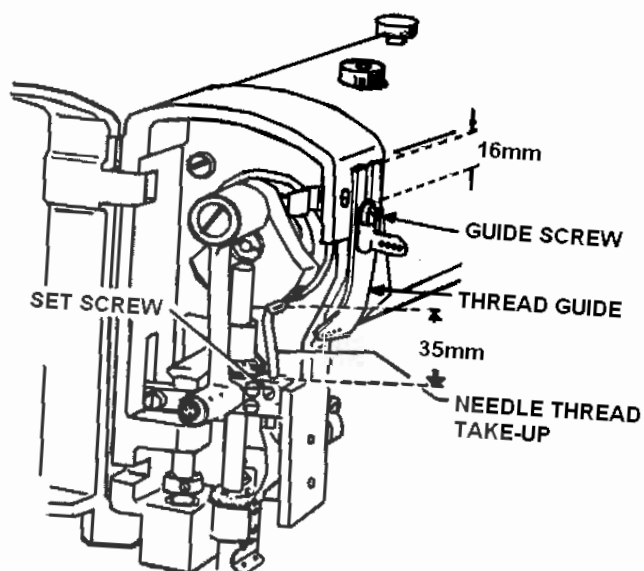

Fig. 30

ADJUSTING NEEDLE THREAD TENSION RELEASER

When correctly adjusted, the tension releaser should release tension on the needle thread when the presser foot is raised and allow full adjusted tension when presser foot is down. To adjust, loosen set screw, Fig. 31, and move tension releaser cap out for earlier release of tension or in for later release. Hold in position and tighten set screw. Should the tension releaser not release tension at the correct time after making the above adjustments, loosen the tension releaser plate screw and move plate sidwise to correct position. Then tighten screw.

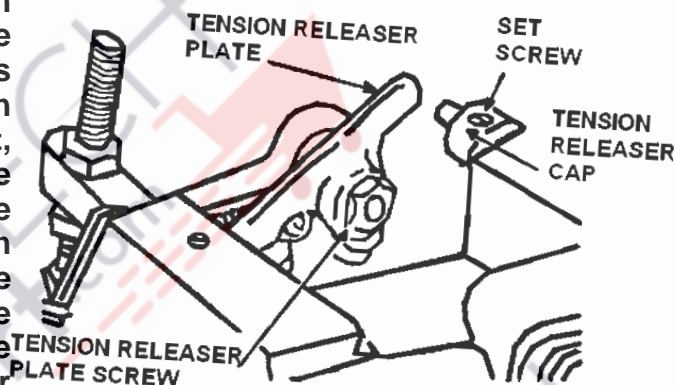

Fig. 31

ADJUSTING LOOPER THREAD TAKE-UP

The looper thread take-up and guide may be adjusted for handling more or less thread, according to thickness of material and length of stitch, and to change the ratio of looper thread in the finished stitch.

To change the amount of thread handled, loosen looper thread guide screw, Fig. 32, looper thread take-up rod screw. Move thread guide and take-up rod to the left for more thread or to the right for less thread. Tighten the two screws making certain that take-up rod passes through the center of the guide yoke.

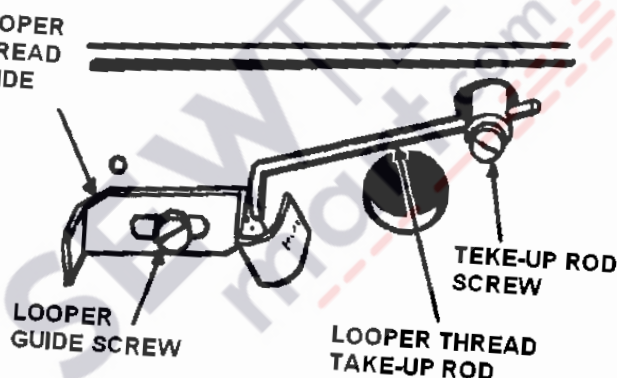
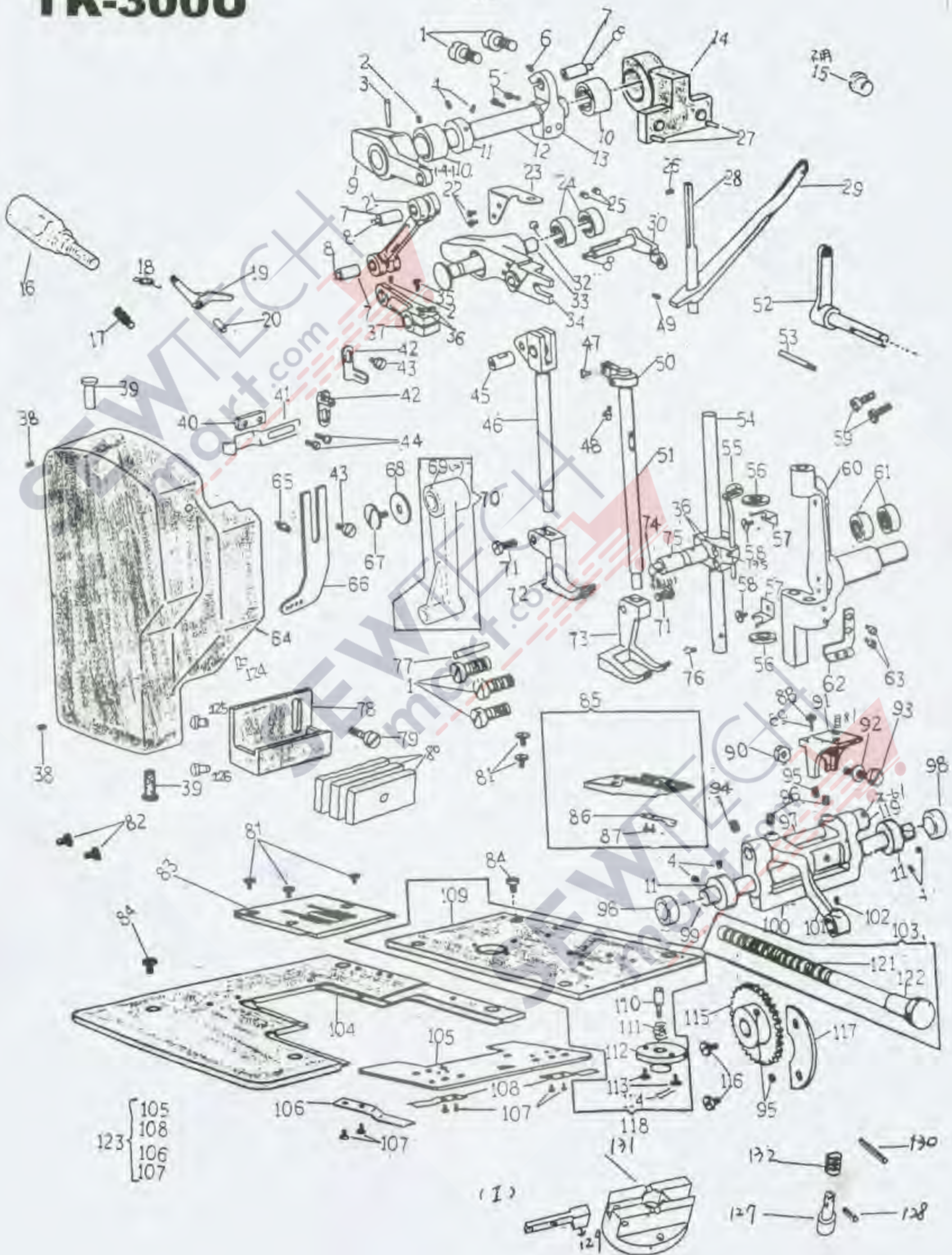

Fig. 32

To change ratio of looper thread in finished stitch, loosen thread guide screw, Fig. 32, and lower the yoke or right end of thread guide for more thread. For less thread, raise end of guide. Hold in position and tighten guide screw.

TK-300U

120 { 9
3
12



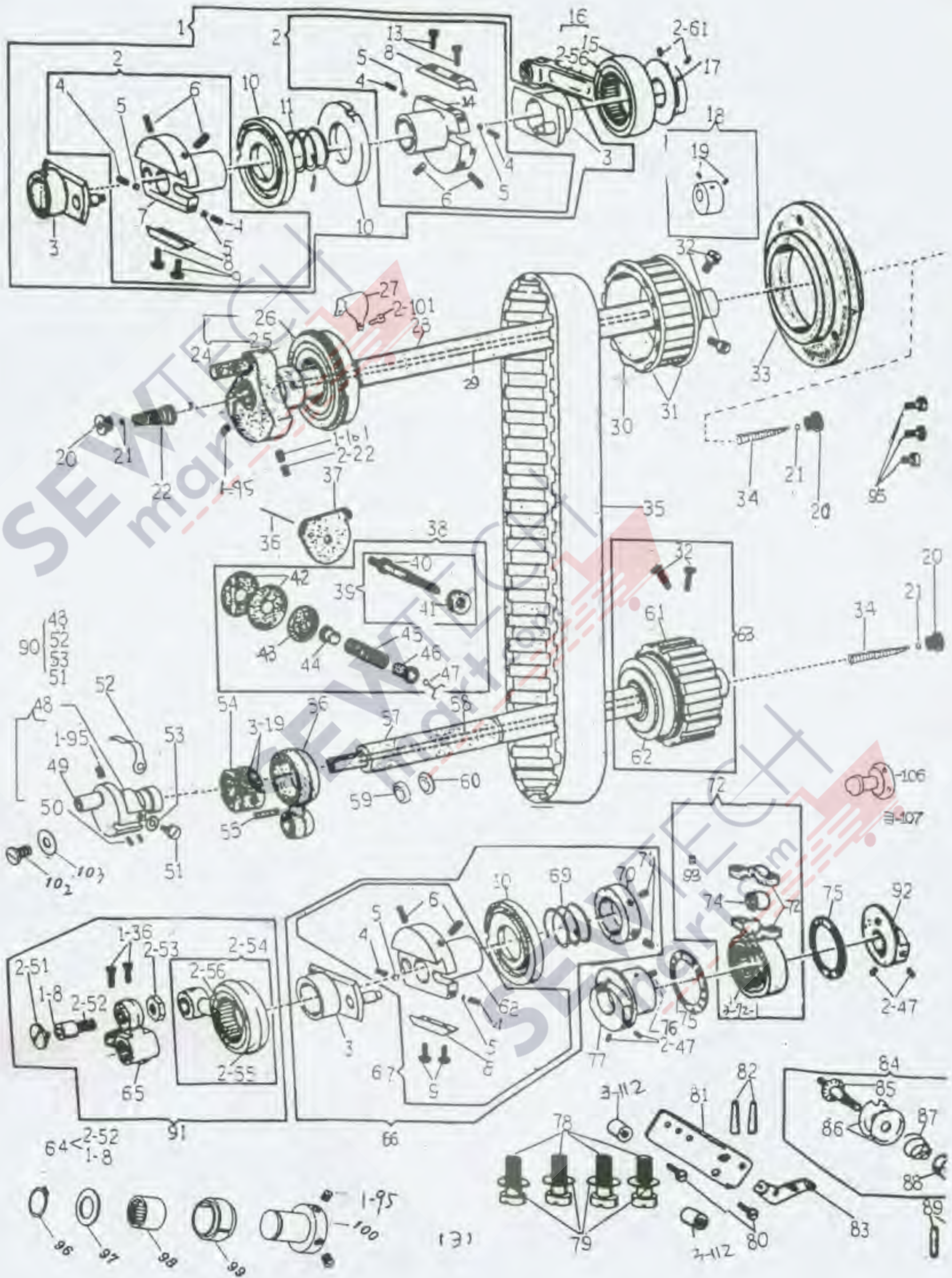

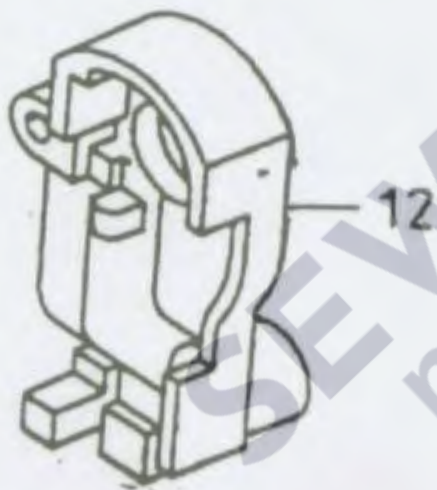
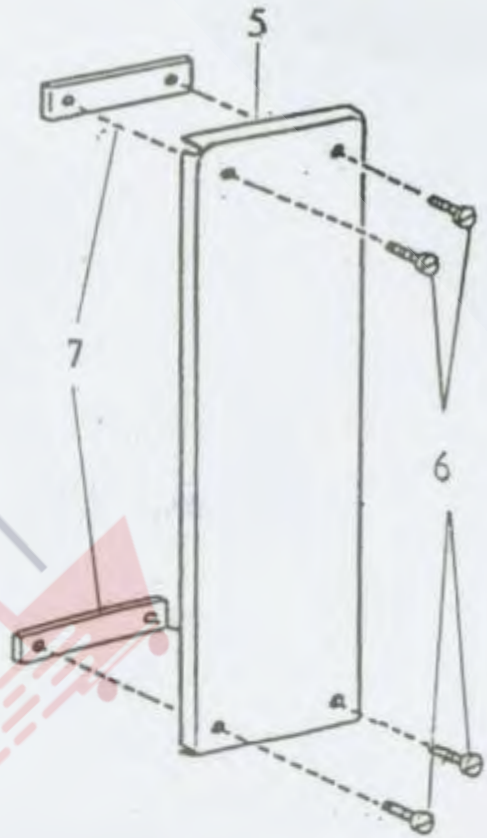
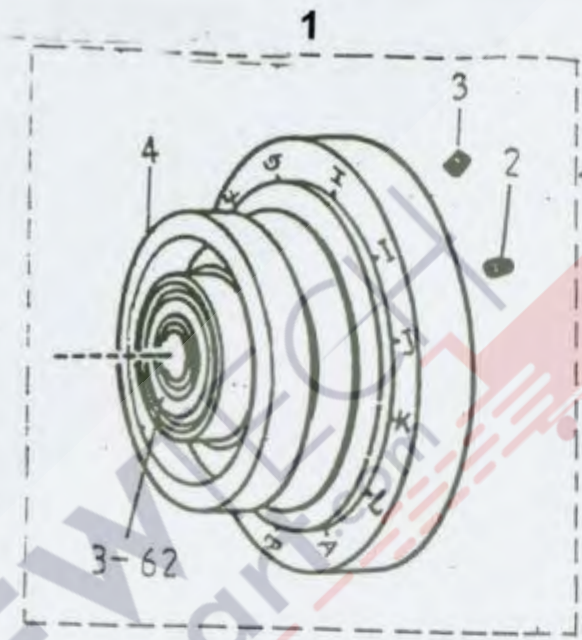

TK-300W PARTS DESCRIPTION

Singer code	Part No.	Description
Page. 1		
414504	1-1	LIFTING ROCK SHAFT BRACKET SCREW
141424	1-2	LIFTING LINK HINGE PIN SET SCREW
548035	1-3	LIFTING ROCK SHAFT CRANK PIN
504020	1-4	LIFTING ROCK SHAFT COLLAR SET SCREW
414509	1-5	FOOT LIFTER ARM PINCH SCREW
414543	1-6	LIFTING ECCENTRIC CONNECTION HINGE PIN PINCH SCREW
267617	1-7	LIFTING LINK HINGE PIN WITH OIL WICK
268258	1-8	LIFTING LINK HINGE PIN OIL PACKING
32788	1-9	LIFTING ROCK SHAFT CRANK
414529	1-9-1	SCREW
267110	1-10	LIFTING ROCK SHAFT NEEDLE BEARING
415065	1-11	LIFTING ROCK SHAFT COLLAR
267633	1-12	LIFTING ROCK SHAFT
415069	1-13	LIFTING ECCENTRIC CONNECTION CRANK
415071	1-14	LIFTING ROCK SHAFT BRACKET
544875	1-15	(NOT USE FOR TAKING TK-300U)
415458	1-16	
414571	1-17	FOOT LEVER (FRONT) SPRING SCREW STUD
203941	1-18	FOOT LIFTER LEVER (FRONT) SPRING
267613	1-19	FOOT LIFTER LEVER (FRONT) WITH HINGE PIN
267614	1-20	FOOT LIFTER LEVER (FRONT) HINGE PIN
267627	1-21	LIFTING LINK
414548	1-22	PRESSER BAR SPRING ARM BALL BEARING RETAINER SCREW
267718	1-23	PRESSER BAR SPRING ARM BEARING RETAINER
267093	1-24	LIFTING LEVER NEEDLE BEARING
544322	1-25	LIFTING LEVER HINGE STUD SET SCREW
544301	1-26	SCREW
543841-001	1-27	LIFTING LOCK SHAFT BRACKET PIN
267907	1-28	LIFTING PRESSER BAR GUIDE ROD
267738	1-29	PRESSER BAR SPRING ARM
267731	1-30	LIFTING PRESSER BAR LIFTING CRANK
	1-31	
267025	1-32	PRESSER BAR SPRING ARM BALL BEARING
267626	1-33	LIFTING LEVER HINGE STUD
415067	1-34	LIFTING LEVER
141338	1-35	LIFTING CRANK SET SCREW
414511	1-36	NEEDLE BAR CONNECTING STUD PINCH SCREW
415061	1-37	LIFTING CRANK
545174-452	1-38	FACE PLATE HINGE STUD SET SCREW
268330	1-39	FACE PLATE HINGE STUD
415016	1-40	FACE PLATE LOCK SPRING PLATE
268032	1-41	FACE PLATE LOCK SPRING
268513	1-42	NEEDLE THREAD GUIDE
414514	1-43	NEEDLE THREAD GUIDE SCREW
414534	1-44	FACE PLATE LOCK SPRING SCREW
267658	1-45	VIBRATING PRESSER BAR HINGE STUD
267657	1-46	VIBRATING PRESSER BAR
414516	1-47	LOOPER CARRIER CRANK HINGE PINCH SCREW
414512	1-48	SCREW
414530	1-49	LIFTING PRESSER BAR GUIDE ROD SET SCREW (LOWER)
415059	1-50	LIFTING PRESSER BAR GUIDE BLOCK
267628	1-51	LIFTING PRESSER BAR FOOT LIFTER CRANK
267612	1-52	FOOT LIFTER CRANK
415041	1-53	FOOT LIFTING CRANK STOP SCREW STUD
415041	1-54	NEEDLE BAR
268512	1-55	NEEDLE THREAD GUIDE
268144	1-56	NEEDLE BAR OILING FELT
268278	1-57	NEEDLE BAR OILING FELT HOLDER
414522	1-58	NEEDLE BAR OILING FELT HOLDER SCREW
350604	1-59	SCREW
415045	1-60	NEEDLE BAR ROCK FRAME

TK-300W PARTS DESCRIPTION

<u>Singer code</u>	<u>Part No.</u>	<u>Description</u>
268029	1-61	NEEDLE BAR ROCK FRAME NEEDLE BEARING
268219	1-62	NEEDLE BAR ROCK FRAME THREAD GUIDE
414539	1-63	NEEDLE BAR ROCK FRAME THREAD GUIDE SCREW
415014	1-64	FACE PLATE (FOR TK-300U-1/2/4)
	1-64-1	FACE PLATE (FOR PORTER STYLE)
	1-64-2	FACE PLATE (FOR TK-300U-1C/2C))
268033	1-65	FACE PLATE LOCK STUD
268312	1-66	NEEDLE THREAD GUIDE
414517	1-67	NEEDLE BAR CONNECTING LINK CAP WASHER SCREW
267139	1-68	NEEDLE BAR CONNECTING LINK CAP WASHER
270266	1-69	NEEDLE BAR CONNECTING LINK BEARING
268056	1-70	NEEDLE BAR CONNECTING LINK ASM
	1-70-1	NEEDLE BAR CONNECTING LINK (SHORT) ASM
414638	1-71	LIFTING PRESSER FOOT PINCH SCREW
267659	1-72	VIBRATING PRESSER FOOT
267632	1-73	LIFTING PRESSER FOOT
202330	1-74	WICK
415053	1-75	NEEDLE BAR CONNECTING STUD
414519	1-76	SCREW
548005	1-77	ARM HEAD POSITION PIN
267656	1-78	THREAD LUBRICATOR
504019	1-79	THREAD LUBRICATOR
236957	1-80	LOOPER THREAD TAKE-UP ROD SET SCREW
414519	1-81	THREAD LUBRICATOR OIL PAD
228661	1-82	FEED PLATE CUSHION (NEOPRENE)
32827	1-83	THROAT PLATE
414508	1-84	BED PLATE SCREW
267664	1-85	FEED DOG
267665	1-86	LOOPER DEFLECTOR
229	1-87	LOOPER DEFLECTOR SCREW
541200	1-88	FEED DOG ADJUSTING SCREW NUT
414559	1-89	FEED DOG ADJUSTING SCREW
545489	1-90	NUT
415208	1-91	FEED DOG SHANK
543804-004	1-92	WASHER
414520	1-93	FEED DOG SHANK SCREW
549024	1-94	FEED DRIVING ROCK FRAME POSITION SCREW
500264-833	1-95	LOOPER DRIVING CRANK SET SCREW
544204-001	1-96	SCREW
268035	1-97	FEED BAR HINGE PIN
415297	1-98	ROLLER
268070	1-99	FEED DRIVING ROCK SHAFT
415200	1-100	FEED DRIVING ROCK FRAME
415198	1-101	FEED BAR
545213	1-102	SCREW
415178	1-103	LOOPER THROW-OUT RACK ROD WITH THUMB NUT
415026	1-104	BED PLATE (LEFT)
415028	1-105	BED PLATE SLIDE
267970	1-106	BED PLATE SLIDE SPRIG
549146	1-107	SCREW
268022	1-108	BED PLATE SLIDE SPRING
415035	1-109	BED PLATE
268081	1-110	FEED REGULATING STUD
270026	1-111	SPRING
268082	1-112	FEED REGULATING STUD SOCKET
545249-452	1-113	FEED REGULATING STUD SOCKET SCREW
240245	1-114	FEED REGULATING RETAINING SPRING
415180	1-115	LOOPER THROW-OUT GEAR
414515	1-116	SCREW
268096	1-117	LOOPER CARRIER SHAFT BUSHING POSITION PLATE
415034-451	1-118	BED PLATE ASM
415202	1-119	FEED BAR HINGE PIN COLLAR
32789	1-120	LIFTING ROCK SHAFT CRANK & PIN

TK-300W PARTS DESCRIPTION

<u>Singer code</u>	<u>Part No.</u>	<u>Description</u>
415179	1-121	LOOPER THROW-OUT RACK ROD

SEWTECH
mart.com

SEWTECH
mart.com

SEWTECH
mart.com

TK-300W PARTS DESCRIPTION

<u>Singer code</u>	<u>Part No.</u>	<u>Description</u>
541451	1-122	LOOPER THROW-OUT RACK ROD THUMB NUT
415027	1-123	BED PLATE SLIDE COMPLETE
414545	1-135	NEEDLE THREAD GUIDE SET SCREW

Page. 2

268505	2-1	LOOPER THREAD GUIDE
50169	2-2	LOOPER THREAD GUIDE BRACKET SCREW
268111	2-3	LOOPER THREAD GUIDE BRACKET
414537	2-4	LOOPER THREAD GUIDE BRACKET SCREW
268506	2-5	THREAD GUIDE
502986	2-6	SCREW
248423	2-7	FOOT LIFTER ROD COTTER PIN
268615	2-8	FOOT LIFTING LEVER ROD
544336	2-9	FOOT LIFTER LEVER SPRING SCREW
204348	2-10	FOOT LIFTING LEVER SPRING
414570	2-11	FOOT LIFTER LEVER SPRING SCREW EYE
414577	2-12	FOOT LIFTER LEVER ROD HINGE SCREW
	2-13	
541166-003	2-14	FOOT LIFTER LEVER ROD HINGE SCREW NUT
567646	2-15	PRESSER BAR SPRING ARM FULCRUM
201363(803)	2-16	FOOT LIFTER LEVER HINGE SCREW
415104	2-17	FOOT LIFTER LEVER
267171	2-18	NEEDLE THREAD TENSION RELEASING PLATE
543850-001	2-19	NEEDLE THREAD TENSION RELEASING PLATE PIN
415120	2-20	FOOT LIFTER ARM
	2-21	
544358	2-22	SCREW
244084	2-23	SCREW
415111	2-24	PRESSER BAR PRESSURE CYLINDER SUPPORT
414579	2-25	PRESSER BAR PRESSURE CYLINDER SUPPORT STUD
541198	2-26	NUT
414523	2-27	SCREW
548459	2-28	WASHER
415107	2-29	PRESSER BAR SPRING BUSHING ASM
415106	2-30A	PRESSER BAR SPRING BUSHING COMPLETE (SMALL)
415116	2-30C	PRESSER BAR SPRING BUSHING COMPLETE (LARGE)
	2-30B	PRESSER BAR SPRING BUSHING COMPLETE (MEDIUM)
415115	2-31	NUT
267655	2-32	WASHER
415114	2-33	PLUNGER
267641	2-34	WASHER
415109	2-35	SPRING
267653	2-36	NUT
267645	2-37	WASHER (NYLON)
415113	2-38	PRESSER BAR SPRING ARM FORK
414567	2-39	PRESSER BAR SPRING ARM HINGE SCREW
548154	2-40	WASHER
545405	2-41	NUT
545205-451	2-42	SCREW
267650	2-43	PRESSER BAR PRESSURE CYLINDER SUPPORT RETAINER
415098	2-44	NEEDLE BAR ROCK FRAME REGULATING STUD COMPLETE
414527	2-45	SCREW
415099	2-46	NEEDLE BAR ROCK FRAME REGULATING STUD CAP
414528	2-47	SCREW
268419	2-48	REGULATING STUD SLEEVE
268148	2-49	NEEDLE BAR ROCK FRAME REGULATING STUD
214529	2-50	REGULATING STUD SPRING
545297	2-51	FEED DRIVING CONNECTION CAP SCREW
415092	2-52	FEED LIFTING CONNECTION HINGE STUD
541197	2-53	NUT
268061	2-54	NEEDLE BAR ROCK FRAME DRIVING CONNECTION & BEARING
268060	2-55	NEEDLE BAR ROCK FRAME DRIVING CONNECTION
415368	2-56	FEED DRIVING CONNECTION NEEDLE BEARING

TK-300W PARTS DESCRIPTION

<u>Singer code</u>	<u>Part No.</u>	<u>Description</u>
415094	2-57	NEEDLE BAR ROCK FRAME DRIVING ARM
414790	2-58	SCREW
	2-59	
415308	2-60	LIFTING ECCENTRIC SPACING COLLAR
414529	2-61	SCREW
504048	2-62	SCREW
415252	2-63	NEEDLE THREAD TENSION RELEASER CAP
415357	2-64	NEEDLE THREAD TENSION RELEASER
204365	2-65	NEEDLE THREAD TENSION RELEASER SPRING
268121	2-66	TENSION BRACKET SPACING COLLAR
268167	2-67	NEEDLE THREAD TENSION BRACKET
545246-452	2-68	ARM SIDE COVER SCREW
545246-452	2-68	SCREW
267604	2-69	ARM SIDE COVER
Cat. 4112-01	2-70	NEEDLE
268382	2-71	LOOPER AND NEEDLE GUARD COMPLETE
141478	2-72	NEEDLE GUARD SET SCREW
268380	2-73	LOOPER
141494	2-74	SCREW
268310	2-75	NEEDLE GUARD
268162	2-76	SPREADER POINT
268638	2-77	SPREADER
414552	2-78	SPREADER SCREW
547670	2-79	SPREADER WASHER
415196	2-80	SPREADER HOLDER
414524	2-81	SCREW
268499	2-82	SPREADER BAR
268190	2-83	SPREADER DRIVING PIN
268184	2-84	SPREADER BAR BRACKET
268079	2-85	FEED LIFTING LINK HINGE PIN
268078	2-86	FEED LIFTING LINK
268131	2-87	LOOPER THROW-OUT SAFETY LATCH
41506	2-88	FEED LIFTING ROCK SHAFT CRANK
267933	2-89	FEED LIFTING ROCK SHAFT
415204	2-90	FEED LIFTING CRANK
414501	2-91	SCREW
543801-012	2-92	LOOPER THROW-OUT SAFETY LATCH RETAINING RING
414549	2-93	SCREW
414553	2-94	LOOPER HOLDER SCREW
414558	2-95	SCREW
417056	2-96	LOOPER HOLDER ASM
415167	2-97	LOOPER CARRIER SHAFT & BUSHING
415168	2-98	LOOPER CARRIER SHAFT BUSHING
268132	2-99	LOOPER THROW-OUT SAFETY LATCH SPRING
268133	2-100	LOOPER THROW-OUT SAFETY LATCH SPRING BRACKET
545205-451	2-101	SCREW
268093	2-102	LOOPER CARRIER SHAFT
268368	2-103	LOOPER CARRIER
268099	2-104	LOOPER DRIVING CONNECTION BUSHING
268208	2-105	LOOPER CARRIER CRANK HINGE PIN
268216	2-106	LOOPER DRIVING CONNECTION ASM
415292	2-107	LOOPER CARRIER CRANK CLAMPING STUD
415174	2-108	LOOPER CARRIER CRANK
545424	2-109	NUT
415192	2-110	SPREADER DRIVING ROCK SHAFT
415194	2-111	SPREADER DRIVING CRANK
414575	2-112	SPREADER DRIVING ROCK SHAFT SCREW STUD
32825	2-113	SPREADER DRIVING ROCK SHAFT SCREW STUD OIL PACKING
268052	2-114	LOOPER THREAD TAKE-UP ROD
268051	2-115	LOOPER THREAD GUIDE
414510	2-116	SCREW
415170	2-117	LOOPER CARRIER SHAFT BUSHING
414556	2-118	LOOPER THREAD GUIDE SCREW

TK-300W PARTS DESCRIPTION

<u>Singer code</u>	<u>Part No.</u>	<u>Description</u>
268373	2-119	LOOPER THREAD GUIDE
414564	2-120	LOOPER THROW-OUT GEAR LOCKING PLANGER STOP SCREW
415182	2-121	LOOPER THROW-OUT GEAR LOCKING PLUNGER
250265	2-122	LOOPER THROW-OUT GEAR LOCKING PLUNGER SPRIN
201477	2-123	LOOPERTHROW-OUT GEAR LOCKING PLUNGER SCREW BUHSING
268313	2-124	LOOPER THROW-OUT GEAR LOCKING PLUNGER HANDLE
541453	2-125	NUT
	2-127	
	2-128	
<hr/>		
Page. 3		
415075	3-1	LIFTING ECCENTRIC AND NEEDLE BAR DRIVING ECCENTRIC COMPLETE
415078	3-2	NEEDLE BAR ROCK FRAME DRIVING ECCENTRIC FLANGE
268064	3-3	FEED DRIVING ECCENTRIC Φ 28-57MM
414557	3-4	SCREW
241763	3-5	SET SCREW PACKING
414555	3-6	SCREW
415079	3-7	NEEDLE BAR ROCK FRAME DRIVING ECCENTRIC FLANGE
267623	3-8	FEED DRIVING ECCENTRIC FRICTION PLATE
374098	3-9	FEED DRIVING ECCENTRIC FRICTION PLATE SCREW
268065	3-10	FEED DRIVING ECCENTRIC ADJUSTING DISC
267618	3-11	LIFTING ECCENTRIC ADJUSTING DISC SPRING
415077	3-12	LIFTING ECCENTRIC FRANGE
544286	3-13	SCREW
415077	3-14	LIFTING ECCENTRIC FLANGE
268492	3-15	LIFTING ECCENTRIC CONNECTION
268493	3-16	LIFTING ECCENTRIC CONNECTION WITH BEARING Φ 28-57MM
415086	3-17	LIFTING ECCENTRIC SPACING COLLAR
	3-18	COLLAR & SCREW
544208-005	3-19	SCREW
414578	3-20	SCREW
268214	3-21	BED SHAFT OIL STOP BALL SCREW
268009	3-22	ARM SHAFT OIL STOP BALL SPRING
500272-833	3-23	SCREW
415132	3-24	NEEDLE BAR CRANK
415133	3-25	NEEDLE BAR CRANK
32848	3-26	ARM SHAFT BALL BEARING
281206	3-27	NEEDLE BAR CRANK COVER
415128	3-28	ARM SHAFT
268264	3-29	ARM SHAFT OIL CONTROL ROD
415157	3-30	ARM SHAFT CONNECTION BELT PULLEY
202253	3-31	ARM SHAFT CONNECTION BELT PULLEY SPRING FLANGE
414546	3-32	SCREW
268004	3-33	ARM SHAFT BALL BEARING HOUSING
268044	3-34	SPRING
268270	3-35	ARM SHAFT CONNECTION BELT
226206	3-36	NEEDLE THREAD TENSION RELEASING PIN
54279	3-37	NEEDLE THREAD TENSION THREAD GUIDE
267971	3-38	NEEDLE THREAD TENSION COMPLETE
59539	3-39	NEEDLE THREAD TENSION STUD WITH THUMB NUT
50326	3-40	NEEDLE THREAD TENSION STUD
54570	3-41	NEEDLE THREAD TENSION THUMB NUT
2102	3-42	TENSION DISC
32572	3-43	NEEDLE THREAD TENSION RELEASING DISC
59538	3-44	TENSION SPRING BUSHING
131741	3-45	NEEDLE THREAD TENSION SPRING
143657	3-46	NEEDLE THREAD TENSION SPRING BUSHING
143658	3-47	NEEDLE THREAD TENSION THUMB NUT LOCKING SPRING
415176	3-48	LOOPER DRIVIING CRANK
410536	3-49	LOOPER DRIVING CRANK OIL STOP SCREW
374099	3-50	LOOPER DRIVING CRANK POSITION SCREW

TK-300W PARTS DESCRIPTION

<u>Singer code</u>	<u>Part No.</u>	<u>Description</u>
545103	3-50	SCREW
374099	3-50	LOOPER DRIVING CRANK POSITION SCREW
414563	3-51	SCREW
268102	3-52	LOOPER DRIVING CRANK OIL HOLE COVER
204925	3-53	SPREADER SCREW WASHER
415210	3-54	FEED LIFTING ECCENTRIC
268077	3-55	FEED LIFTING ECCENTRIC LUBRICATING PAD
268074	3-56	FEED LIFTING CONNECTION
415145	3-57	BED SHAFT
268265	3-58	BED SHAFT OIL CONTROL ROD
268029	3-59	NEEDE BEARING
268029	3-60	NEEDLE BEARING
415160	3-61	BED SHAFT CONNECTING BELT PULLEY
272140	3-62	ARM SHAFT BALL BEARING (BACK)
415159	3-63	BED SHAFT CONNECTION BELT PULLEY WITH BEARING
415091	3-64	NEEDLE BAR ROCK FRAME DRIVING CONNECTION HINGE STUD
415213	3-65	FEED DRIVING ROCK SHAFT CRANK
415072	3-66	FEED DRIVING ECCENTRIC COMPLETE
415073	3-67	FEED DRIVING FLANGE ASM
415074	3-68	FEED DRIVING FLANGE
268066	3-69	ECCENTRIC ADJUSTING DISC SPRING
412011	3-70	FEED LIFTING ECCENTRIC
544325	3-71	SCREW
415183	3-72	SPREADER DRIVING CONNECTION WITH BEARRING & BALL ROLLER
	3-72-1	BEARING
415569	3-73	SCREW
351876	3-74	SPREADER DRIVING ROCK SHAFT SCREW STUD BALL ROLLER
268220	3-75	SPREADER DRIVING ECCENTRIC THRUST WASHER
543808-002	3-76	SCREW
415187	3-77	SPREADER DRIVING ECCENTRIC
415361	3-78	ARM SCREW
543804-007	3-79	ARM SCREW WASHER
414532	3-80	SCREW
415255	3-81	LOOPER THREAD TENSION BRACKET
415295	3-82	ARM POSITION PIN
268333	3-83	LOOPER THREAD TENDION THREAD GUIDE
415294	3-84	LOOPER THREAD TENSION COMPLETE
415291	3-85	LOOPER THREAD TENSION STUD
412203	3-86	LOOPER THREAD TENSION DISC
10148	3-87	LOOPER THREAD TENSION SPRING
541452	3-88	LOOPER THREAD TENSION THUMB NUT
228448	3-89	MACHINE LOCATING STUD
415350	3-90	LOOPER DRIVING CRANK ASM
415212	3-91	FEED DRIVING CRANK & NEEDLE BAR DRIVING CONNECTION
415190	3-92	SPREADER DRIVING ECCENTRIC COUNTER BLALANCE
	3-93	SCREW
415368	3-94	FEED DRIVING CONNECTION NEEDLE BEARING
544336	3-95	SCREW
	3-101	SCREW
	3-102	SCREW
	3-103	WASHER
	3-106	
268121	3-112	

Page. 4

415153-451	4-1	MACHINE PULLEY
414526	4-2	SCREW
414525	4-3	SCREW
415154	4-4	MACHINE PULLEY
415342	4-5	BED SHAFT BALL BEARING
414639	4-6	SCREW
268500	4-7	LOOPER THREAD GUIDE GASKET
268123	4-8	LOOPER THREAD TUBE

TK-300W PARTS DESCRIPTION

<u>Singer code</u>	<u>Part No.</u>	<u>Description</u>
415009	4-12	BELL CASTING FRONT FACE

SEWTECH
mart.com

SEWTECH
mart.com

SEWTECH
mart.com

SEWTECH
mart.com

SEWTECH
mart.com

SEWTECH
mart.com

TAKING

大慶縫衣機械股份有限公司



TA KING INDUSTRIAL CO., LTD

8F, No. 230, Sec. 3, Cheng Teh Road,

P. O. Box 21~41, Taipei, Taiwan

E-mail: taking@ms14.hinet.net

Tel: 886-2-25950288 Fax:886-2-25919233